



VIBRATION ANALYSIS HARDWARE



LP802 Series Product Manual

TABLE OF CONTENTS

- Introduction.....3
- Intrinsically Safe Information4
- Product Specifications5
- Dimension Drawings5
- Wiring.....6
- Measurement7
- Installation8
- Warranty and Return Information9



INTRODUCTION

4-20 mA Vibration Monitoring Process Overview

4-20 mA technology can be used to measure temperature, pressure, flow and speed, as well as the overall vibration of rotating machines. Adding a vibration sensor/transmitter to the machine provides a critical measure of the machine's health. It can be used to identify changes in balance, alignment, gears, bearings, and many other potential faults. The purpose of the 4-20 mA analog current loop is to transmit the signal from an analog vibration sensor over a distance in the form of a 4-20 mA current signal. The current signal generated is proportional to the overall vibration of the equipment or machinery that is being monitored. This output current has a range of 4-20 mA, with 4 representing the minimum and 20 representing maximum amplitudes (within the range of 4-20 mA). The 4-20 mA signal output is proportional to the overall amplitude generated within a defined frequency band. Therefore, the signal does not include data from frequencies outside the frequency band but includes all vibration (critical and non-critical faults) within that band.

LP802 Series Overview

Each LP802 sensor that is approved for Intrinsic Safety must meet or exceed the requirements for standards recognized by the countries that would use the sensors.

Specific Conditions of Use:

Specific ambient conditions of use include -40°F to 176°F (-40°C to 80°C) for all LP Series

Special Conditions for Safe Use:

None



INTRINSICALLY SAFE INFORMATION

Compliance with the Essential Health and Safety Requirements

Assured by compliance with EN60079-0:2004, EN60079-11:2007, EN60079-26:2007, EN61241-0:2006, EN61241-11:2007

ATEX Related Nameplate Markings

The following is a complete recapitulation of ATEX nameplate markings so the customer has complete ATEX information for specific conditions of use.



II 1 G/D

KEMA 04 ATEX 1066



Class 1 Div 1 (Zone 0) Labeling

INTRINSICALLY SAFE
SECURITE INTRINSEQUE

Ex ia IIC T3 / T4

Ex iaD A20 T150 °C (T-Code = T3) / T105 °C (T-Code = T4)
DIP A20 IP6X T150 °C (T-Code = T3) / T105 °C (T-Code = T4)

AEx ia IIC T3 / T4

AEx iaD 20 T150 °C (T-Code = T3) / T105 °C (T-Code = T4)

CLI GPS A,B,C,D

CLII, GPS E,F,G, CLIII

CLI, ZONE 0, ZONE 20

OPERATING TEMP CODE: T4

AMBIENT TEMP RANGE = -40 °C TO +80 °C

CONTROL DRAWING INS10012

Ex ia IIC T3 -54 °C < Ta < +125 °C

Ex ia IIC T4 -40 °C < Ta < +80 °C

Ui=28V_{DC} Ii=100mA

Ci=70nF Li=51µH Pi=1W

CSA 221421

KEMA 04ATEX1066

LP80*, and LP90* Series – Temperature Code: T4

Ambient temperature range = -40 °C to 80 °C



PRODUCT SPECIFICATIONS

Power Input	15-30 Vdc supply voltage required
Band-Pass Filter	The vibration sensor contains a band-pass filter, consisting of a low-pass and a high-pass.
Analog Output	Full-scale output of 4-20 mA
Operation	Filters the signal, and normalizes the output to the specified full-scale output. Performs a true RMS conversion and transmits this data in a 4-20 mA format (if RMS is chosen).
Temperature Range	-40°F to 176°F (-40°C to 80°C)

DIMENSION DRAWINGS

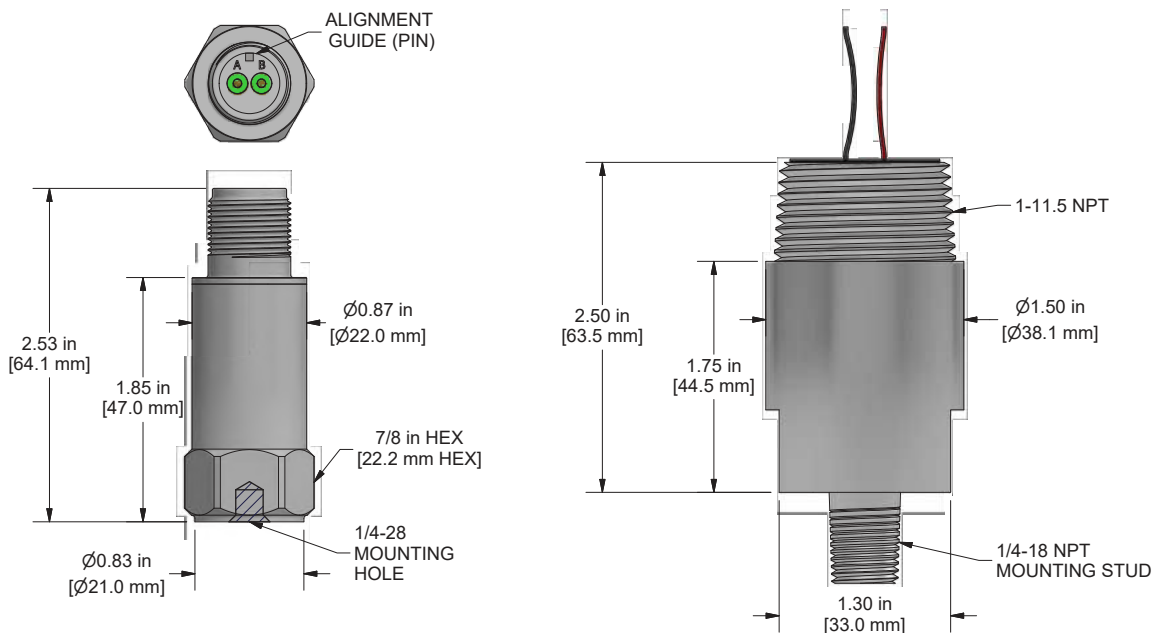

WIRING

The Intrinsic Safety Control Drawing INS10012 below shows the installation requirements for CTC IS Sensors. As shown, properly installed barriers are required to limit the energy the sensor can receive. Cabling brings the signal from the sensor to the Zener diode barrier or galvanic isolator, which is the energy-limiting interface. The signal is transferred through the barrier (which can be located in a Class I Div 2 or non-hazardous area) to measurement equipment, such as a data collector or junction box, for further processing.

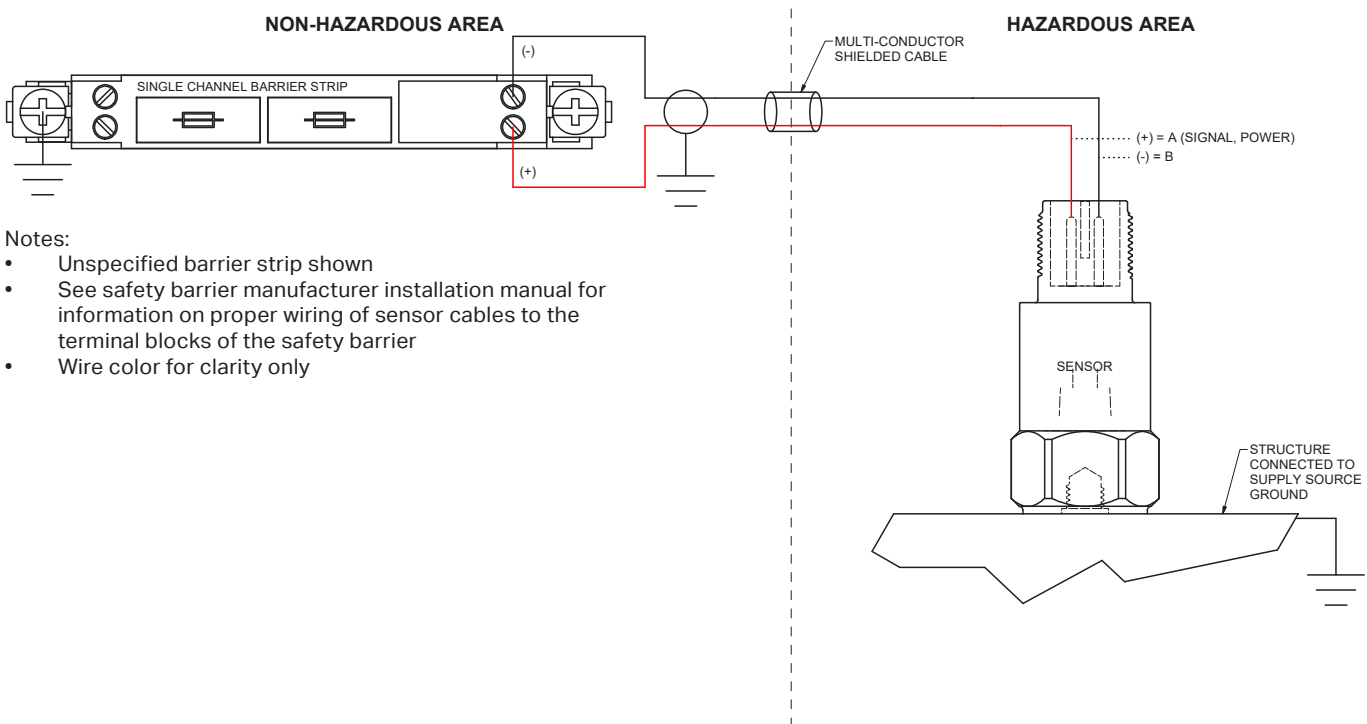

- Notes:
- Unspecified barrier strip shown
 - See safety barrier manufacturer installation manual for information on proper wiring of sensor cables to the terminal blocks of the safety barrier
 - Wire color for clarity only

Loop Resistance Calculations

Standard Loop Powered Sensors

$$R_L (\text{max}) = \frac{V_p - 15 \text{ V} \times (1 \text{ mA} / .001 \text{ A})}{20 \text{ mA}}$$

***Intrinsically Safe Loop Powered Sensors**

$$R_L (\text{max}) = \frac{V_p - 12 \text{ V} \times (1 \text{ mA} / .001 \text{ A})}{20 \text{ mA}}$$

*Note: Typical Loop Powered Circuit will include an Intrinsically Safe Barrier in the Circuit

Power Source Voltage (V_p)	Typical R_L (max) (Non-IS Sensors)	Typical R_L (max) (IS Sensors)
20	250	100
24	450	300
26	550	400
30	750	600



MEASUREMENT

FULL-SCALE MEASUREMENT RANGE	ACTUAL VIBRATION, IPS	EXPECTED OUTPUT (mA)
0 - 0.4 IPS (0 - 10 mm/s)	0	4
	0.1 (2.5 mm/s)	8
	0.2 (5.0 mm/s)	12
	0.3 (7.5 mm/s)	16
	0.4 (10.0 mm/s)	20
0 - 0.5 IPS	0	4
	0.1	7.2
	0.2	10.4
	0.3	13.6
	0.4	16.8
	0.5	20
0 - 0.8 IPS (0 - 20 mm/s)	0	4
	0.2 (5.0 mm/s)	8
	0.4 (10.0 mm/s)	12
	0.6 (15.0 mm/s)	16
	0.8 (20.0 mm/s)	20
0 - 1.0 IPS (LP800 Series)	0	4
	0.1	5.6
	0.25	8
	0.5	12
	0.75	16
	1	20
0 - 2.0 IPS (LP800 Series)	0	4
	0.25	6
	0.5	8
	0.75	10
	1	12
	1.25	14
	1.5	16
	1.75	18
	2	20



INSTALLATION

Tighten the sensor to the mounting disk using **2 to 5 ft-lbs of mounting force**.



- The mounting torque is important to the frequency response of the sensor for the following reasons:
 - If the sensor is not tight enough, proper coupling between the base of the sensor and the mounting disk will not be achieved.
 - If the sensor is over tightened, stud failure may occur.
- A coupling agent (such as MH109-3D epoxy) will maximize the high frequency response of your hardware, but is not required.

Permanent/Stud Mounting Surface Preparation

1. Prepare flat surface using a spot face tool and pilot drill hole using a CTC spot face installation tool.
2. The mounting surface should be clean and free from any residue or paint.
3. Tap for required thread (1/4-28 or M6x1).
4. Install sensor.
 - Suggested Installation Tool Kit: MH117-1B

WARRANTY AND REFUND

Warranty

All CTC products are backed by our unconditional lifetime warranty. If any CTC product should ever fail, we will repair or replace it at no charge.

Refund

All stock products can be returned for a 25% restocking fee if returned in new condition within 90 days of shipment. Stock products qualify for free cancellation if your order is cancelled within 24 hours of purchase. Built-to-order products qualify for a 50% refund if returned in new condition within 90 days of shipment. Custom products are quoted and built specifically to the requirements of the customer, which may include completely custom product designs or private labeled versions of standard products for OEM customers. Custom products ordered are non-cancellable, non-returnable and non-refundable.

