

MH134-1A

Accelerometer Mounting Pad with Zerk Grease Fitting Adapter,
1/4" Tapped Hole, 1/4-18 NPT Mounting Thread



VIBRATION ANALYSIS HARDWARE



Product Features

Sensors can be magnet or stud mounted directly into Zerk grease fitting adapter

- ▶ Magnet mount or permanent mount accelerometers directly to top of Zerk adapter
- ▶ Zerk fitting included
- ▶ Stainless Steel case material

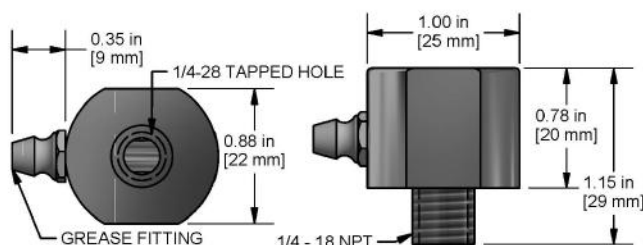

Specifications

Case Material	17-4 Stainless Steel
Dimensions	1.15 in (29 mm) x 1.0 in (25 mm) x 0.88 in (22 mm)
Sensor Mounting	1/4-28 Mounting Hole
Field Mounting	1/4-18 NPT Adapter Mounting Thread

Chemical Compatibilities for Reference

- ▶ Gasoline - A
- ▶ Methanol - A
- ▶ Lubricants - A

Compatibility

- ▶ Compatible with all sensors with 1/4"-28 mounting stud or adapter
- ▶ Conversion mounting studs sold separately

Stock Product

Backed by our Unconditional Lifetime Warranty

www.ctconline.com | sales@ctconline.com | 585-924-5900

MH134-1B



VIBRATION ANALYSIS HARDWARE

Accelerometer Mounting Pad with 45° Zerk Grease Fitting Adapter,
1/4-28 Tapped Hole, 1/4-18 NPT Mounting Thread



Product Features

Sensors can be magnet or stud mounted directly into Zerk grease fitting adapter

- ▶ Magnet mount or permanent mount accelerometers directly to top of Zerk adapter
- ▶ 45° Zerk fitting included
- ▶ Stainless Steel Case Material

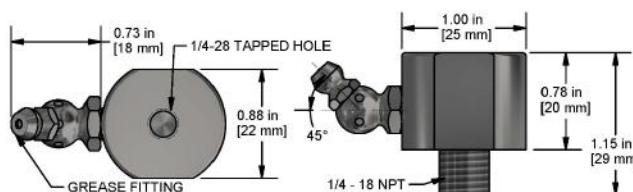

Specifications

Case Material	17-4 Stainless Steel
Dimensions	1.15 in (29 mm) x 1.0 in (25 mm) x .88 in (22 mm)
Sensor Mounting	1/4-28 Mounting Hole
Field Mounting	1/4-18 NPT Adapter Mounting Thread

Chemical Compatibilities for Reference

- ▶ Gasoline - A
- ▶ Methanol - A
- ▶ Lubricants - A

Compatibility

- ▶ Compatible with all sensors with 1/4-28 mounting studs and adapters
- ▶ Conversion mounting studs sold separately

Stock Product

Backed by our Unconditional Lifetime Warranty

www.ctconline.com | sales@ctconline.com | 585-924-5900

MH134-2A

Accelerometer Mounting Pad with Zerk Grease Fitting Adapter,
1/4" Tapped Hole, 1/8" NPT Mounting Thread



VIBRATION ANALYSIS HARDWARE



Product Features

Sensors can be magnet or stud mounted directly into Zerk grease fitting adapter

- ▶ Magnet mount or permanent mount accelerometers directly to top of Zerk adapter
- ▶ Zerk fitting included
- ▶ Stainless Steel case material

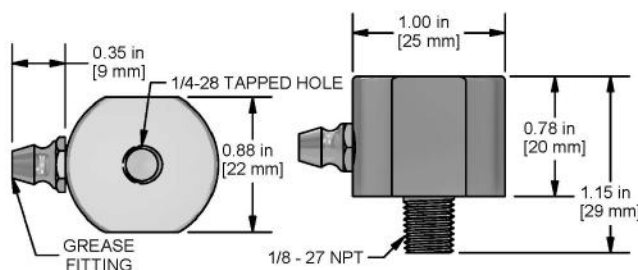

Specifications

Case Material	17-4 Stainless Steel
Dimensions	1.15 in (29 mm) x 1.0 in (25 mm) x 0.88 in (22 mm)
Sensor Mounting	1/4-28 Mounting Hole
Field Mounting	1/8" NPT Adapter Mounting Thread

Chemical Compatibilities for Reference

- ▶ Gasoline - A
- ▶ Methanol - A
- ▶ Lubricants - A

Compatibility

- ▶ Compatible with any accelerometer with a 1/4-18 stud or adapter
- ▶ Conversion mounting studs sold separately

Stock Product

Backed by our Unconditional Lifetime Warranty

www.ctconline.com | sales@ctconline.com | 585-924-5900

MH134-2B



VIBRATION ANALYSIS HARDWARE

Accelerometer Mounting Pad with 45° Zerk Grease Fitting Adapter,
1/4-28 Tapped Hole, 1/8-27 NPT Mounting Thread



Product Features

Sensors can be magnet or stud mounted directly into Zerk grease fitting adapter

- ▶ Magnet mount or permanent mount accelerometers directly to top of Zerk adapter
- ▶ 45° Zerk fitting included
- ▶ Stainless Steel Case Material

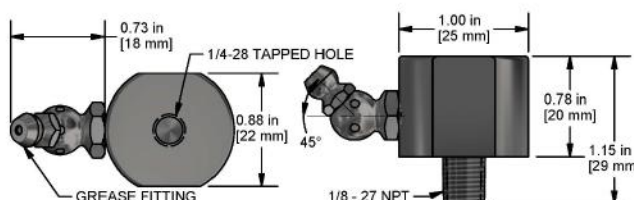

Specifications

Case Material	17-4 Stainless Steel
Dimensions	1.15 in (29 mm) x 1.0 in (25 mm) x .88 in (22 mm)
Sensor Mounting	1/4-28 Mounting Hole
Field Mounting	1/8-27 NPT Adapter Mounting Thread

Chemical Compatibilities for Reference

- ▶ Gasoline - A
- ▶ Methanol - A
- ▶ Lubricants - A

Compatibility

- ▶ Compatible with any accelerometers with 1/4-28 stud or adapter
- ▶ Conversion mounting studs sold separately

Stock Product

Backed by our Unconditional Lifetime Warranty

www.ctconline.com | sales@ctconline.com | 585-924-5900

MH134-3A



VIBRATION ANALYSIS HARDWARE

Accelerometer Mounting Pad with Zerk Grease Fitting Adapter,
1/4" Tapped Hole, 1/4" SAE-LT Mounting Thread



Product Features

Sensors can be magnet or stud mounted directly into Zerk grease fitting adapter

- ▶ Magnet mount or permanent mount accelerometers directly to top of Zerk adapter
- ▶ Zerk fitting included
- ▶ Stainless Steel case material

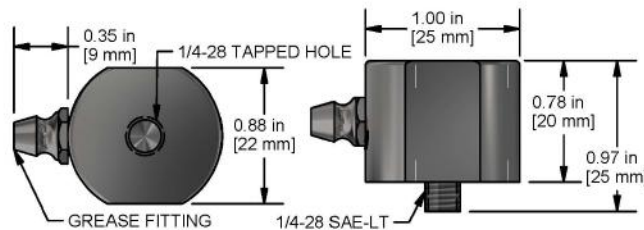

Specifications

Case Material	17-4 Stainless Steel
Dimensions	0.97 in (25 mm) x 1.0 in (25 mm) x 0.88 in (22 mm)
Sensor Mounting	1/4-28 Mounting Hole
Field Mounting	1/4-28 SAE-LT Adapter Mounting Thread

Chemical Compatibilities for Reference

- ▶ Gasoline - A
- ▶ Methanol - A
- ▶ Lubricants - A

Compatibility

- ▶ Compatible with any accelerometers with 1/4-28 stud or adapter
- ▶ Conversion mounting studs sold separately

Stock Product

Backed by our Unconditional Lifetime Warranty

www.ctconline.com | sales@ctconline.com | 585-924-5900

MH134-3B



VIBRATION ANALYSIS HARDWARE

Accelerometer Mounting Pad with 45° Zerk Grease Fitting Adapter, 1/4-28 Tapped Hole, 1/4" SAE-LT Mounting Thread



Product Features

Sensors can be magnet or stud mounted directly into Zerk grease fitting adapter

- ▶ Magnet mount or permanent mount accelerometers directly to top of Zerk adapter
- ▶ 45° Zerk fitting included
- ▶ Stainless Steel case material

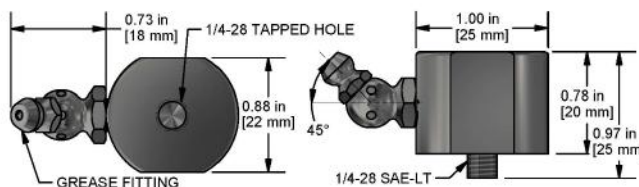

Specifications

Case Material	17-4 Stainless Steel
Dimensions	0.97 in (25 mm) x 1.0 in (25 mm) x 0.88 in (22 mm)
Sensor Mounting	1/4-28 Mounting Hole
Field Mounting	1/4-28 SAE-LT Adapter Mounting Thread

Chemical Compatibilities for Reference

- ▶ Sea Water - C
- ▶ Salt Water - B
- ▶ Vinegar - A

Compatibility

- ▶ Compatible with any accelerometers with 1/4-28 stud or adapter
- ▶ Conversion mounting studs sold separately

Stock Product

Backed by our Unconditional Lifetime Warranty

www.ctconline.com | sales@ctconline.com | 585-924-5900

MH134-4A



VIBRATION ANALYSIS HARDWARE

Hex Head Accelerometer Mounting Pad with Zerk Grease Fitting Adapter, 1/4-28 Tapped Hole, 1/4-18 NPT Mounting Thread



Product Features

Sensors can be magnet or stud mounted directly into Zerk grease fitting adapter

- ▶ Magnet mount or permanent mount accelerometers directly to top of Zerk adapter
- ▶ Zerk fitting included
- ▶ Stainless steel case material

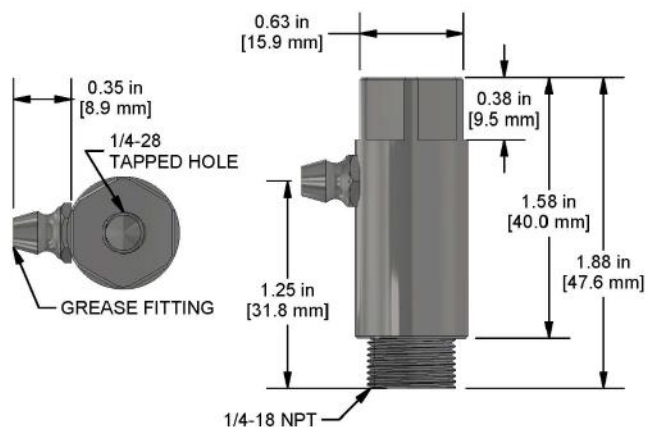

Specifications

Case Material	17-4 Stainless Steel
Dimensions	1.88 in (47.6 mm) x 0.63 in (15.9 mm)
Sensor Mounting	1/4-28 Mounting Hole
Field Mounting	1/4-18 NPT Adapter Mounting Thread

Chemical Compatibilities for Reference

- ▶ Gasoline - A
- ▶ Methanol - A
- ▶ Lubricants - A

Compatibility

- ▶ Compatible with any accelerometers with 1/4-28 stud or adapter
- ▶ Conversion mounting studs sold separately

Stock Product

Backed by our Unconditional Lifetime Warranty

www.ctconline.com | sales@ctconline.com | 585-924-5900

MH134-4B



VIBRATION ANALYSIS HARDWARE

Hex Head Accelerometer Mounting Pad with 45° Zerk Grease Fitting Adapter, 1/4-28 Tapped Hole, 1/4-18 NPT Mounting Thread



Product Features

Sensors can be magnet or stud mounted directly into Zerk grease fitting adapter

- ▶ Magnet mount or permanent mount accelerometers directly to top of Zerk adapter
- ▶ 45° Zerk fitting included
- ▶ Stainless steel case material

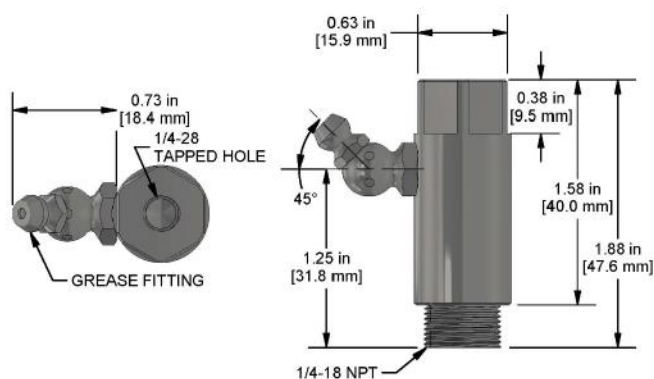

Specifications

Case Material	17-4 Stainless Steel
Dimensions	1.88 in (47.6 mm) x 0.63 in (15.9 mm)
Sensor Mounting	1/4-28 Mounting Hole
Field Mounting	1/4-18 NPT Adapter Mounting Thread

Chemical Compatibilities for Reference

- ▶ Gasoline - A
- ▶ Methanol - A
- ▶ Lubricants - A

Compatibility

- ▶ Compatible with any accelerometers with 1/4-28 stud or adapter
- ▶ Conversion mounting studs sold separately

Stock Product

Backed by our Unconditional Lifetime Warranty

www.ctconline.com | sales@ctconline.com | 585-924-5900

MH134-5A



VIBRATION ANALYSIS HARDWARE

Hex Head Accelerometer Mounting Pad with Zerk Grease Fitting Adapter, 1/4-28 Tapped Hole, 1/8-27 NPT Mounting Thread



Product Features

Sensors can be magnet or stud mounted directly into Zerk grease fitting adapter

- ▶ Magnet mount or permanent mount accelerometers directly to top of Zerk adapter
- ▶ Zerk fitting included
- ▶ Stainless steel case material

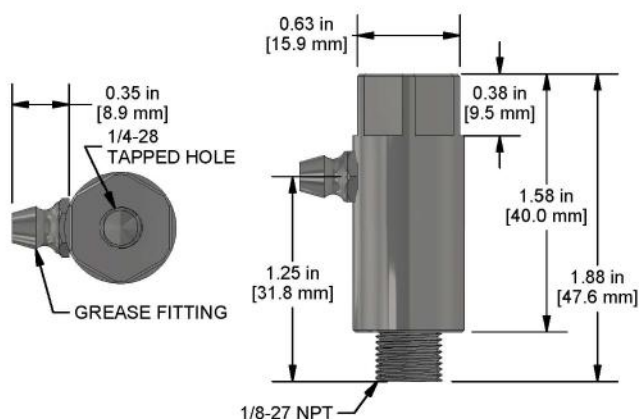

Specifications

Case Material	17-4 Stainless Steel
Dimensions	1.88 in (47.6 mm) x 0.63 in (15.9 mm)
Sensor Mounting	1/4-28 Mounting Hole
Field Mounting	1/8-27 NPT Adapter Mounting Thread

Chemical Compatibilities for Reference

- ▶ Gasoline - A
- ▶ Methanol - A
- ▶ Lubricants - A

Compatibility

- ▶ Compatible with any accelerometers with 1/4-28 stud or adapter
- ▶ Conversion mounting studs sold separately

Stock Product

Backed by our Unconditional Lifetime Warranty

www.ctconline.com | sales@ctconline.com | 585-924-5900

MH134-5B



VIBRATION ANALYSIS HARDWARE

Hex Head Accelerometer Mounting Pad with 45° Zerk Grease Fitting Adapter, 1/4-28 Tapped Hole, 1/8-27 NPT Mounting Thread



Product Features

Sensors can be magnet or stud mounted directly into Zerk grease fitting adapter

- ▶ Magnet mount or permanent mount accelerometers directly to top of Zerk adapter
- ▶ 45° Zerk fitting included
- ▶ Stainless steel case material

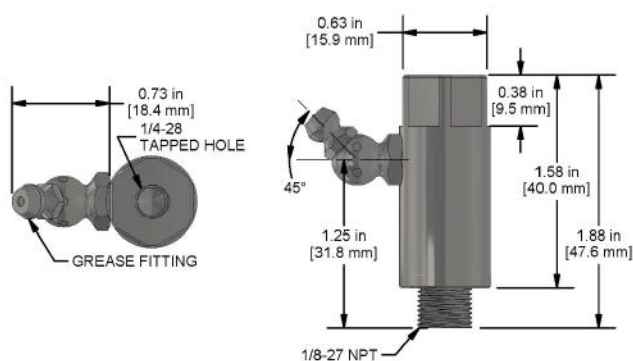

Specifications

Case Material	17-4 Stainless Steel
Dimensions	1.88 in (47.6 mm) x 0.63 in (15.9 mm)
Sensor Mounting	1/4-28 Mounting Hole
Field Mounting	1/8-27 NPT Adapter Mounting Thread

Chemical Compatibilities for Reference

- ▶ Gasoline - A
- ▶ Methanol - A
- ▶ Lubricants - A

Compatibility

- ▶ Compatible with any accelerometers with 1/4-28 stud or adapter
- ▶ Conversion mounting studs sold separately

Stock Product

Backed by our Unconditional Lifetime Warranty

www.ctconline.com | sales@ctconline.com | 585-924-5900

MH134-6A



VIBRATION ANALYSIS HARDWARE

Hex Head Accelerometer Mounting Pad with Zerk Grease Fitting Adapter, 1/4-28 Tapped Hole, 1/4" SAE-LT Mounting Thread



Product Features

Sensors can be magnet or stud mounted directly into Zerk grease fitting adapter

- ▶ Magnet mount or permanent mount accelerometers directly to top of Zerk adapter
- ▶ Zerk fitting included
- ▶ Stainless steel case material

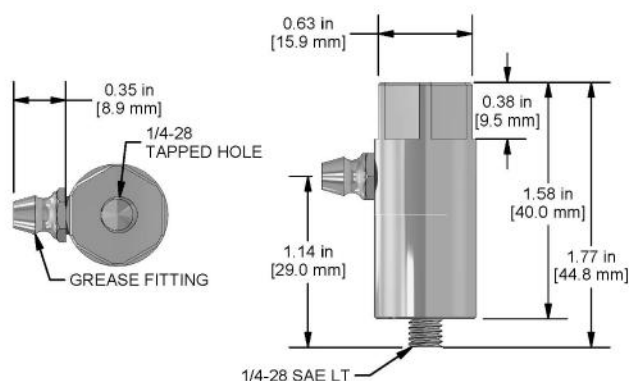

Specifications

Case Material	17-4 Stainless Steel
Dimensions	1.77 in (44.8 mm) x 0.63 in (15.9 mm)
Sensor Mounting	1/4-28 Mounting Hole
Field Mounting	1/4-28 SAE-LT Adapter Mounting Thread

Chemical Compatibilities for Reference

- ▶ Gasoline - A
- ▶ Methanol - A
- ▶ Lubricants - A

Compatibility

- ▶ Compatible with any accelerometers with 1/4-28 stud or adapter
- ▶ Conversion mounting studs sold separately

Stock Product

Backed by our Unconditional Lifetime Warranty

www.ctconline.com | sales@ctconline.com | 585-924-5900

MH134-6B



VIBRATION ANALYSIS HARDWARE

Hex Head Accelerometer Mounting Pad with 45° Zerk Grease Fitting Adapter, 1/4-28 Tapped Hole, 1/4" SAE-LT Grease Fitting Thread



Product Features

Sensors can be magnet or stud mounted directly into Zerk grease fitting adapter

- ▶ Magnet mount or permanent mount accelerometers directly to top of Zerk adapter
- ▶ 45° Zerk fitting included
- ▶ Stainless steel case material

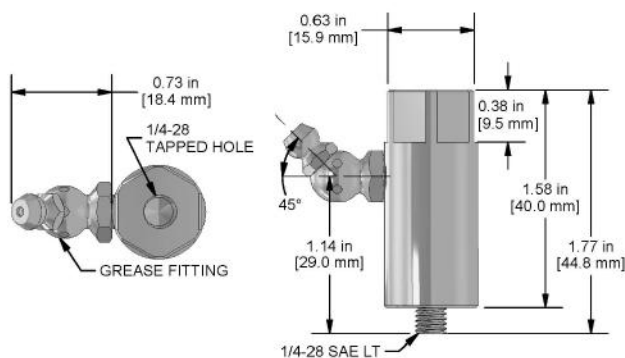

Specifications

Case Material	17-4 Stainless Steel
Dimensions	1.77 in (44.8 mm) x 0.63 in (15.9 mm)
Sensor Mounting	1/4-28 Mounting Hole
Field Mounting	1/4-28 SAE-LT Adapter Mounting Thread

Chemical Compatibilities for Reference

- ▶ Gasoline - A
- ▶ Methanol - A
- ▶ Lubricants - A

Compatibility

- ▶ Compatible with any accelerometers with 1/4-28 stud or adapter
- ▶ Conversion mounting studs sold separately

Stock Product

Backed by our Unconditional Lifetime Warranty

www.ctconline.com | sales@ctconline.com | 585-924-5900

MH145-1B

Accelerometer Mounting Pad with Button Head Grease Fitting Adapter, 1/8-27 NPT Mounting Thread



VIBRATION ANALYSIS HARDWARE

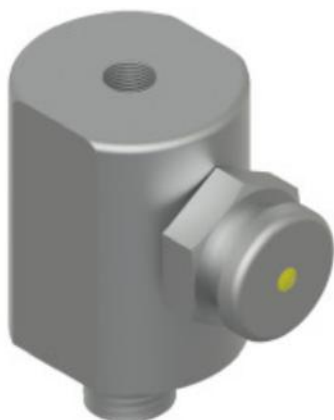

Product Features

Sensor Can Be Mounted Directly into a Grease Fitting Location

- ▶ 1/4-28 Accelerometer mounting hole
- ▶ Zerk fitting included
- ▶ Stainless steel case material

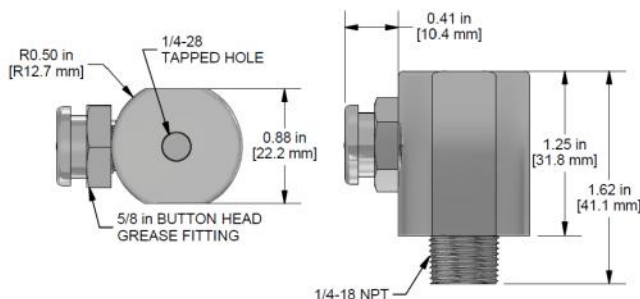

Specifications

Case Material	Stainless Steel
Dimensions	1.62 in (41 mm) x 0.88 in (22 mm)
Sensor Mounting	1/8-27 NPT Mounting Thread 1/4-28 Accelerometer Mounting Hole

Chemical Compatibilities for Reference

- ▶ Gasoline - A
- ▶ Methanol - A
- ▶ Lubricants - A

Compatibility

- ▶ Compatible with any accelerometer with 1/4-28 stud or adapter
- ▶ Conversion mounting studs available

Stock Product

Backed by our Unconditional Lifetime Warranty

www.ctconline.com | sales@ctconline.com | 585-924-5900